

## NEW Clad King Dual Circuit [320kg]

A dual circuit vacuum cladding lifter specifically developed for the safe, quick, handling and installation of composite wall and roof panels.

The Clad King features a **dampened hydraulic tilt mechanism** allowing panels to be safely tilted from horizontal to vertical. Multi-positional pads and an extendable frame add to the lifter's versatility making it suitable for all panel types - PUR, mineral wool and EPS - and most surface finishes.

Aluminium multi-configuration frame offers minimal load deflection.



Cable Remote Control

### Technical Specifications

<b>Vacuum system</b>	dual circuit:	1 pump, 2 vacuum tanks
<b>Suitable for lifting</b>	material properties:	gastight, other materials possible but subject to test
	surface:	smooth or slightly structural
	example:	composite panels (PUR, EPS, mineral wool), glass, sheet metals and plastics
<b>Suction cup type</b>	approx:	457mm x 203mm
<b>Suction cup quality</b>	description:	black rubber with closed cell foam seal
<b>Number of suction cups</b>	cups:	6
<b>Loading capacity of frame</b> (on smooth and clean surface at 60% vacuum)	vertical:	320kg
	horizontal:	320kg
<b>Weight of lifter</b>	approx:	118kg (136kg with extension arms)
<b>Structural depth</b>	approx:	440mm
<b>Output</b>	approx:	1.5m <sup>2</sup> /h
<b>Voltage</b>	pump:	12v DC from rechargeable battery
	battery charger:	110v/240v 50/60Hz single phase factory selectable
<b>Standard accessories</b>	standard:	4 x extension arms, reverse air flow (blow-off), dampened tilting
<b>Optional accessories</b>	optional:	cable remote control, radio remote control, replaceable foam pad seals, adjustable lifting bail

# Clad King

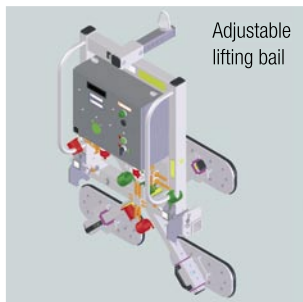

Adjustable lifting bail





Developed for use with Kingspan insulated panels



- Dual, independent vacuum circuits with two vacuum reserve tanks and two non-return valves
- Vacuum gauge for each circuit
- Hydraulically dampened tilting
- Lockable vertical and horizontal tilting
- On-board maintenance-free vacuum pump
- 12v rechargeable battery with integral 110v or 240v charger and battery energy gauge
- Audio-visual low vacuum alert
- Cable remote control option
- Reverse air flow (blow-off) vacuum pump
- Multi-positional pads to fit between panel ridges
- Frame extendable to 4.66m length



Dual Circuit Clad King - Code VCL05

Technical Data

